

8 7 6 5 4 3 2 1

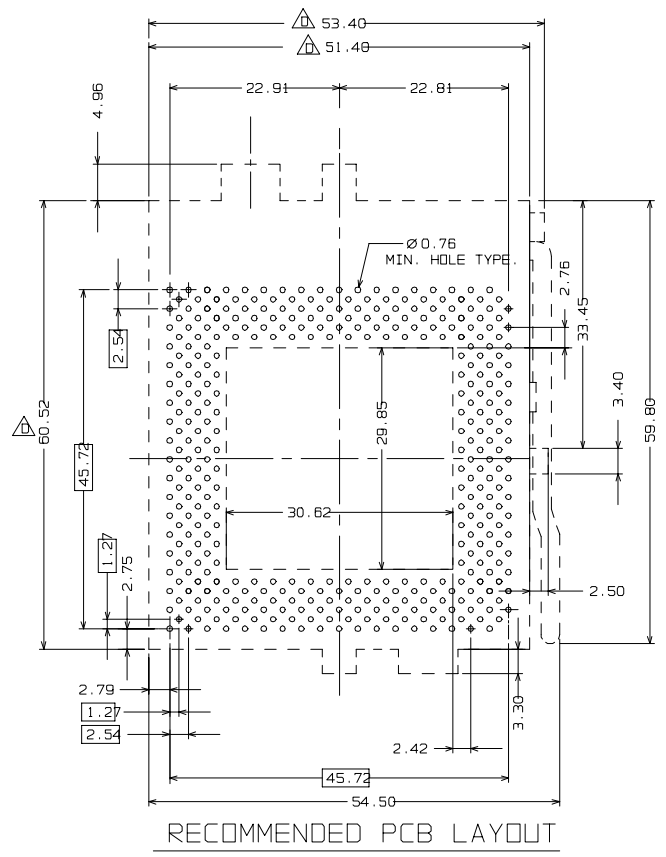
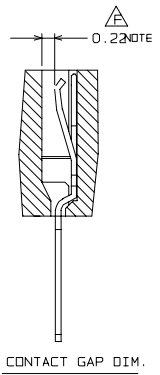
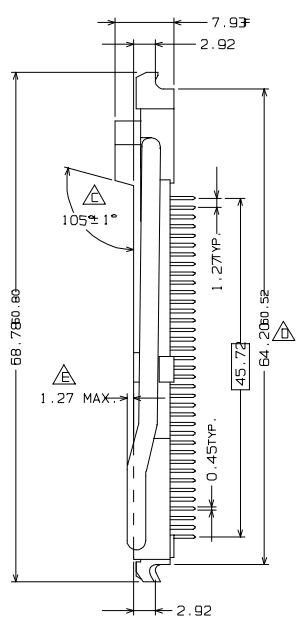
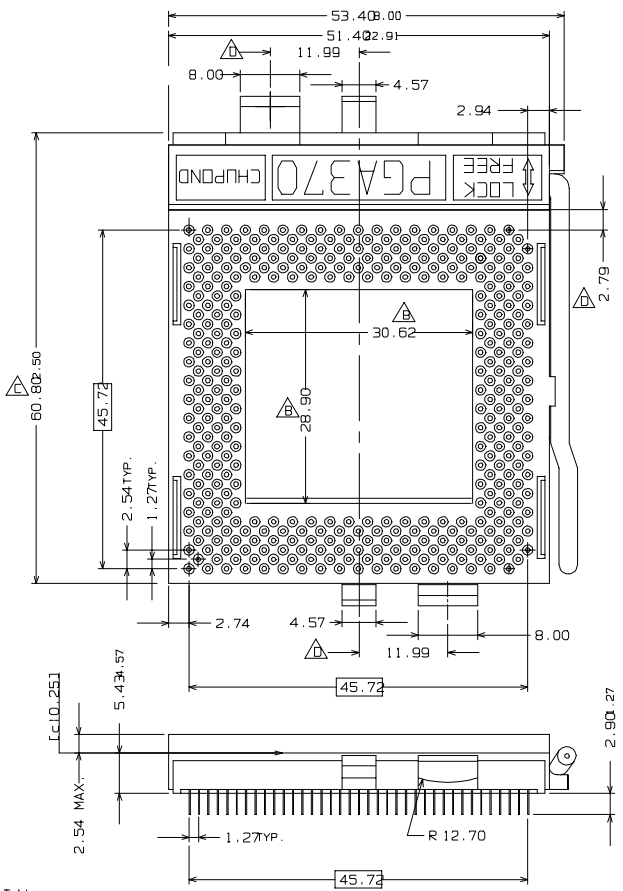

**NOTE**

1 MATERIAL:  
 BASE : REINFORCED THERMOPLASTIC LCP,UL 94V-0 RATED.  
 COVER : REINFORCED THERMOPLASTIC LCP,UL 94V-0 RATED.  
 CONTACT : HI-STRENGTH COPPER ALLOY.  
 ACTUATOR : STAINLESS STEEL ROD.

2 CONTACT PLATING:  
 \* GOLD PLATING IN CONTACT AREA,OVER 50u" NICKEL UNDER PLATING.  
 \* TIN/LEAD 100u" IN SOLDER TAIL OVER 50u" NICKEL.

DO NOT SCALE DRAWING

LTR	REVISION RECORD	ECR	ECN	DRG	CHK	DATE
F	CONTACT GAP DIM.(0.2+0.1/-0±0.05 0.22+/-0.1)	990018	990018	LJ,H		990505
E	HANDLE DIM. REVISE	990016	990016	LJ,H		990416
D	DIM. REVISE	990010	990010	LJ,H		990208
C	Heatsink tab & Cover DIM. Revised	990008	990008	LJ,H		990201
B	WINDOW & HANDLE AREA REVISE	990005	990005	LJ,H		990118
A	RELEASE TO PRODUCTION			LJ,H		981002

CUSTOMER COPY

DRAWN BY: LJ,H      CHK'D BY:

APP'D BY:              SCALE: NONE

GENERAL TOLERANCES DIM. : .25 ANGLE : 3°	CHUPOND PRECISION CO., LTD.
FILE NAME 067XX19370-CUS	SHEET 1 OF 1
TITLE : PGA370 SOCKET	
DWG. NO. : 067-XX-19370	REV F